



European Technical Assessment **ETA 21/0677** of 08/02/2022

I General Part

Technical Assessment Body issuing the ETA	Eurofins Expert Services Oy
Trade name of the construction product	Lumon® Glazing Retractable Standard Lift Handle, Lumon® Glazing Retractable Standard Handle, Lumon® Glazing Retractable Strong Lift Handle, Lumon® Glazing Retractable Strong Handle, Lumon® Glazing Retractable Strong Low Threshold Handle
Product family to which the construction product belongs	Balcony and Terrace Glazing System
Manufacturer	Lumon Oy Kaitilankatu 11 FI-45130 Kouvola
Manufacturing plant	Lumon Oy Kaitilankatu 11 FI-45130 Kouvola
This European Technical Assessment contains	13 pages including an Annex which forms an integral part of this assessment
This European Technical Assessment is issued in accordance with regulation (EU) No 305/2011, on the basis of	EAD 020002-00-0404 Balcony (and Terrace) Glazing System without vertical Frames
This version replaces	ETA 21/0677 issued on 09.08.2021

Translations of this European Technical Assessment in other languages shall fully correspond to the original issued document and should be identified as such.

Communication of this European Technical Assessment, including transmission by electronic means, shall be in full excepted the confidential Annex(es) referred to above. However, partial reproduction may be made, with the written consent of the issuing Technical Assessment Body. Any partial reproduction has to be identified as such.

II Specific Part

1 Technical description of the product

The balcony and terrace glazing system consists of two horizontal aluminium profiles which are fixed to balcony's ceiling and balustrade or floor. There are normal and stronger profiles depending on loads and size of panels. There is also a version with lower Lower profile. It is called Lumon® Glazing Retractable Strong Low Threshold. Toughened glass panes are attached to the profiles through separate mechanisms which allow the panes to slide and turn.

Aluminium glazing beads are fastened to the upper and lower edges of the panes with the help of flanges which have been installed to the upper and lower edges of the pane. Fastening is secured by gluing. The upper and lower glazing beads are provided with components which enable sliding and opening of glasses. There are normal and stronger components depending on loads and size of panel. System with stronger profiles and components is called Lumon® Glazing Retractable Strong.

The first pane is opened by unlocking. The glazing can be provided with a lock. The other panes can be moved by sliding and turning. When the panes are turned, their hinges lock to the hinges of the open pane. The glazing can hence be opened completely. On Land U-balconies, glass panes can slide round +90° ... -270° corners.

Thicknesses of glass panes are 8, 10 or 12 mm depending on the glass panel size and wind load resistance requirements. Most usual panel widths are 600 - 1000 mm. The minimum width of the glass pane is 300 mm and maximum width is 1000 mm. Maximum height of the glass panes is 2877 mm. The edges and possible drillings are made according to the standard EN 12150-1. If requested, the glass panes can be delivered also as heat soaked.

The upper profile is attached to the ceiling with screw and wedges or through a telescopic profile or to the overhang with mounting brackets. The lower profile is attached with mounting brackets or through the bottom of the profile to the balustrade structure or to the floor. Fastening of the glazing system into balcony or terrace floor and roof shall be done according to the type of the surrounding construction and instructions of the manufacturer. The fastenings are not part of this ETA.

Corrosion-resistant fasteners must be used.

Rainwater is drained off by using water sills made of plastic-coated steel sheet or aluminium sheet.

A seal is used to close the gap between the glass pane and the wall. Example drawings of the glazing system are in the Annex 1.

2 Specification of the intended uses in accordance with the applicable EAD

Intended uses

The balcony glazing is used to protect balcony or terrace interior from rain, snow, wind and dirt. The glazed balcony is not warm or half warm space. It is not totally water tight or air tight.

The system can be fastened into concrete, brick, steel, aluminium or timber substrates.

The system is not intended to act as barrier against falling. In case of risk of falling, a separate barrier is needed that shall fulfil local requirements concerning safety.

Working life and durability

The provisions made in this ETA are based on an assumed working life of the balcony glazing system of 25 years¹.

Design

Glass pane thickness and pane sizes are chosen case by case based on structural design calculations made by the manufacturer who has design tables or software for the purpose. In the design, local regulations concerning wind pressure and safety shall be taken into account. This European technical assessment is based on the assumption that the design has been made correctly according to the regulations valid on the building site.

Execution of construction works

The completed building (the works) shall comply with the building regulations (regulations on the works) applicable in the Member States in which the building is to be constructed. The procedures foreseen in the Member State for demonstrating compliance with the building regulations shall also be followed by the entity held responsible for this act. An ETA for a balcony glazing system does not concern this process in any way.

¹ This means that it is expected that when this working life has elapsed, the real working life may be, in normal use conditions, considerably longer without major degradation affecting the essential requirements of the works. The indications given as to the working life of a Lumon® Glazing Retractable balcony and terrace glazing system cannot be interpreted as a guarantee given by the producer or the assessment body. They should only be regarded as a means for the specifiers to choose the appropriate criteria for balcony glazing systems in relation to the expected, economically reasonable working life of the works.

3 Performance of the product and references to the methods used for its assessment

Table 1. Basic requirements for construction works and essential characteristics

Basic requirement and essential characteristics	Performance
BWR 3. Hygiene, health and the environment	
Ventilation and dampness	Clause 3.1
BWR 4. Safety and accessibility in use	
Resistance to wind load	Clause 3.2
Impact resistance	Clause 3.2
Properties of glass panes and other parts	Clause 3.2
<ul style="list-style-type: none">• Corrosion resistance	Clause 3.2
<ul style="list-style-type: none">• Resistance to racking	No performance assessed
<ul style="list-style-type: none">• Resistance to static torsion	No performance assessed
BWR 5. Protection against noise	
Airborne sound insulation	No performance assessed

3.1 Hygiene, health and environment, BWR 3

Ventilation and dampness

The air gaps between the glass panes ensure air permeability of the glazing, which diminish risk of dampness or condensation. Width of the air gaps between the glass panes are 2-3 mm.

3.2 Safety and accessibility in use, BWR 4

Resistance to wind load

Glass pane thickness and pane size are chosen case by case based on structural design calculations made by the manufacturer. Results of the tested samples are given below.

Table 2. Dimensions and resistance to wind load of the tested¹ glazing systems

	Max. height of the pane mm	Width of glass units mm	Thickness of glass mm	max test pressure ² inward (+) Pa	max test pressure ² outward (-) Pa	Pressure P3 ³ estimated Pa	Pressure P1 ⁴ estimated Pa	Relative deflection ⁵ estimated
Lumon® Glazing Retractable Standard Lift Handle	2063	1000	6	800	900	800	500	0,05
	2363	1000	8	1200	1100	1100	700	0,04
	1663	1000	10	4200	4500	4200	2800	0,04
	2863	665	10	1200	1500	1200	800	0,04
Lumon® Glazing Retractable Standard Handle	2063	1000	6	800	900	800	500	0,04
	2363	1000	8	1100	1200	1100	700	0,04
	1663	1000	10	3800	4400	3800	2500	0,03
	2863	665	10	1300	1400	1300	800	0,04
Lumon® Glazing Retractable Strong Lift Handle	2360	1000	8	1000	1300	1000	600	0,04
	2860	1000	10	1100	1200	1100	700	0,04
	1660	1000	12	5700	5900	5700	3800	0,04
	2860	800	12	1700	1700	1700	1100	0,03
Lumon® Glazing Retractable Strong Handle	2360	1000	8	1100	1000	1000	600	0,04
	2860	1000	10	1100	1200	1100	700	0,04
	1660	1000	12	5300	5300	5300	3500	0,03
	2860	800	12	2000	1900	1900	1200	0,04
Lumon® Glazing Retractable Strong Low Threshold Handle	2377	665	8	1200	1100	1100	700	0,04
	2877	665	10	1300	1200	1200	800	0,04
	1677	665	12	4500	4100	4100	2700	0,02
	2877	665	12	1500	1700	1500	1000	0,03

¹ The tests were carried out by ift Rosenheim. The method described in EN 12211 was modified and for example the dynamic test phase using P2 was not performed.

² Maximum pressure value without damage inward (+) and outward (-) was defined by testing.

³ Pressure value P3 was estimated to be the smaller value of max pressure without damage.

⁴ Pressure value P1 was calculated to be P3/1,5 and rounded down to the nearest hundred.

⁵ For calculating the relative deflection the higher deflection corresponding the P1 was chosen from test records.

Impact resistance

Classification of the impact resistance of Lumon® Glazing Retractable balcony and terrace glazing system. Dimensions of the glass pane in all tests were width x height: 876 mm x 1938 mm.

Table 3. Impact resistance of Lumon® Glazing Retractable

	Thickness of glass pane mm	Drop height mm	Class according to EN 13049
Lumon® Glazing Retractable Standard Lift Handle	8	450	3
	10	450	3
Lumon® Glazing Retractable Standard Handle	8	200	1
	10	450	3
Lumon® Glazing Retractable Strong Lift Handle	8	450	3
	10	450	3
	12	900	4
Lumon® Glazing Retractable Strong Handle	8	200	1
	10	450	3
	12	450	3
Lumon® Glazing Retractable Strong Low Threshold Handle without lock in the middle	8	200	1
	10	450	3
	12	450	3
Lumon® Glazing Retractable Strong Low Threshold Handle with lock in the middle	8	200	1
	10	200	1
	12	200	1

Properties of glass panes and other parts

UV-radiation resistance

Changes of dimensions are non-existent or relatively small as well as the changes of weight. Plastic parts showed light changes to colour, which does not affect the functionality of the components.

Corrosion resistance

The metallic components have at least moderate corrosion resistance in mild environments.

4 Assessment and verification of constancy of performance (hereinafter AVCP) system applied, with reference to its legal base

For the products covered by this ETA the applicable European legal act is: Decision 96/580/EC

The system to be applied is: 3.

5 Technical details necessary for the implementation of the AVCP system, as provided for in the applicable EAD.

Technical details necessary for the implementation of the AVCP system are laid down in the control plan deposited at Eurofins Expert Services Oy.

Issued in Espoo on February 8, 2022
by Eurofins Expert Services Oy

Katja Vahtikari
Manager, Construction Certification

Saija Korpjaakko
Expert, Product Certification

ANNEX 1 Main components and Example Drawings

Table 4. Main components of the balcony glazing system

Component	Specification	Remarks	
Aluminium: upper and lower profiles, telescope profiles and glazing beads, extension profiles (EN AW-6063 T6)	EN 10204	Certificate of compliance with the order "2.1"	
<ul style="list-style-type: none"> • polyester powder coated or • anodised 	EN 573-3		
	EN 755-2		
Glass	EN 572-2	Certificate of compliance with the order Thermally toughened soda lime silicate glass Heat soaked if requested.	
<ul style="list-style-type: none"> • thermally toughened float glass 	EN 12150-1		
Hinges and sliding parts: Polyamide		Property data sheets by the raw material producer	
Lift Handle, Handle: metallic / polyamide other plastic parts		Property data sheets by the raw material producer	
<ul style="list-style-type: none"> • Follower • Upper and lower chamber, polyamide • Latches: metallic / polyamide • Rail guide, polyamide • Additional locking component LGR: polyamide 			
Seals			Can be changed
<ul style="list-style-type: none"> • Silicone / PVC / TPE / PP 			

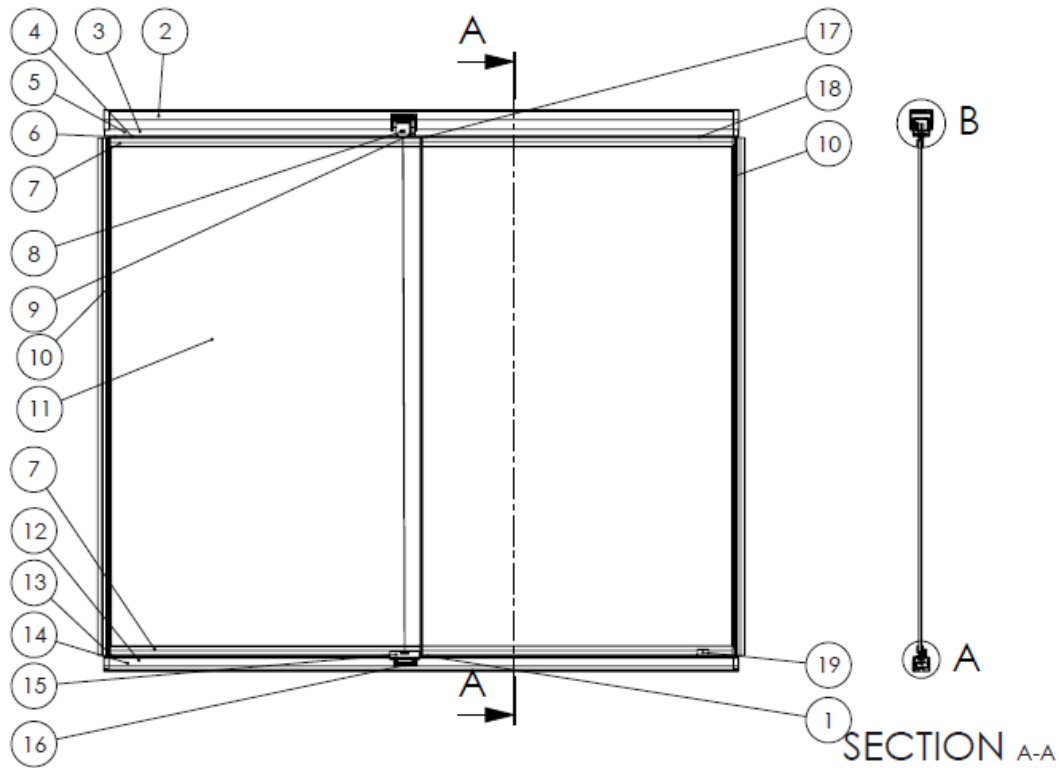

	Item number	Name	
1	50240002	Lower hinge LGR	Plastic
2	11222206	Telescopic profile L5/LGR	Aluminium
3	11241205	Upper profile LGR	Aluminium
4	53240020	Additional locking component LGR	Plastic
5	53240015	Upper chamber 6 LGR	Plastic
6	50240007	Upper rail guide R LGR	Plastic
7	11245232 11245233 11255234	Glazing bead 6mm LGR Glazing bead 8mm LGR Glazing bead 10mm LGR	Aluminium
8	50240008	Upper latch LGR	Plastic
9	53240021	Follower L LGR	Plastic
10	54042024	Edge seal 30mm	Silicon
11		Toughened glass 6mm Toughened glass 8mm Toughened glass 10mm	Glass
12	11243001	Lower profile LGR	Aluminium
13	50240001	Lower start hinge LGR	Plastic
14	50240012	Lower chamber 6 LGR	Plastic
15	50240009	Lower latch LGR	Plastic / Aluminium
16	53240013	Lower hole frame LGR	Plastic
17	50240004	Upper hinge L LGR	Plastic
18	50240006	Upper rail guide L LGR	Plastic
19	50240003	Lower rail guide LGR	Plastic

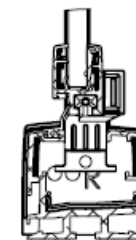

DETAIL A
SCALE 1:2

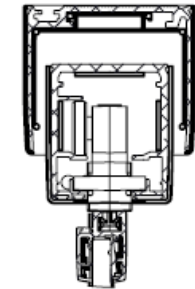

DETAIL B
SCALE 1:2

Figure 1. Example drawing of Lumon® Glazing Retractable Standard Lift Handle

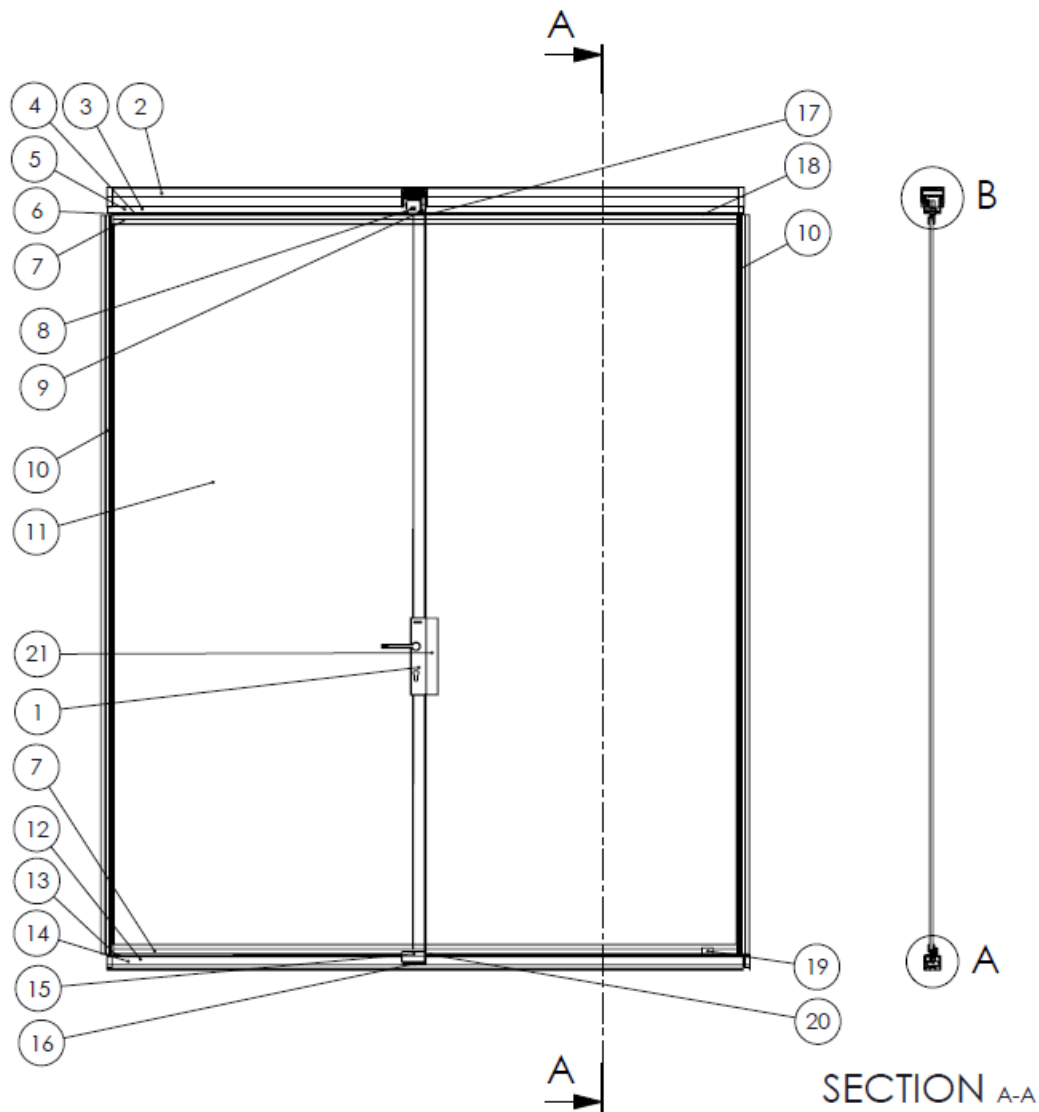

	Item number	Name	
1	50250006	Lock L	Aluminium / steel
2	11222206	Telescopic profile L5/LGR	Aluminium
3	11241205	Upper profile LGR	Aluminium
4	53240020	Additional locking component LGR	Plastic
5	53240015	Upper chamber 6 LGR	Plastic
6	50240007	Upper rail guide R LGR	Plastic
7	11245232 11245233 11255234	Glazing bead 6mm LGR Glazing bead 8mm LGR Glazing bead 10mm LGR	Aluminium
8	50240008	Upper latch LGR	Plastic
9	53240021	Follower L LGR	Plastic
10	54042024	Edge seal 30mm	Silicon
11		Toughened glass 6mm Toughened glass 8mm Toughened glass 10mm	Glass
12	11243001	Lower profile LGR	Aluminium
13	50240001	Lower start hinge LGR	Plastic
14	50240012	Lower chamber 6 LGR	Plastic
15	50240009	Lower latch LGR	Plastic
16	53240013	Lower hole frame LGR	Plastic
17	50240004	Upper hinge L LGR	Plastic
18	50240006	Upper rail guide L LGR	Plastic
19	50240003	Lower rail guide LGR	Plastic
20	50240002	Lower hinge LGR	Plastic
21	50250010	Glass counterpart	Aluminium

SECTION A-A

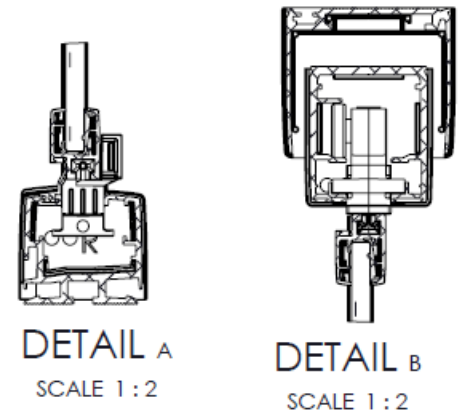

DETAIL A
SCALE 1:2

DETAIL B
SCALE 1:2

Figure 2. Example drawing of Lumon® Glazing Retractable Middle Handle with Lock

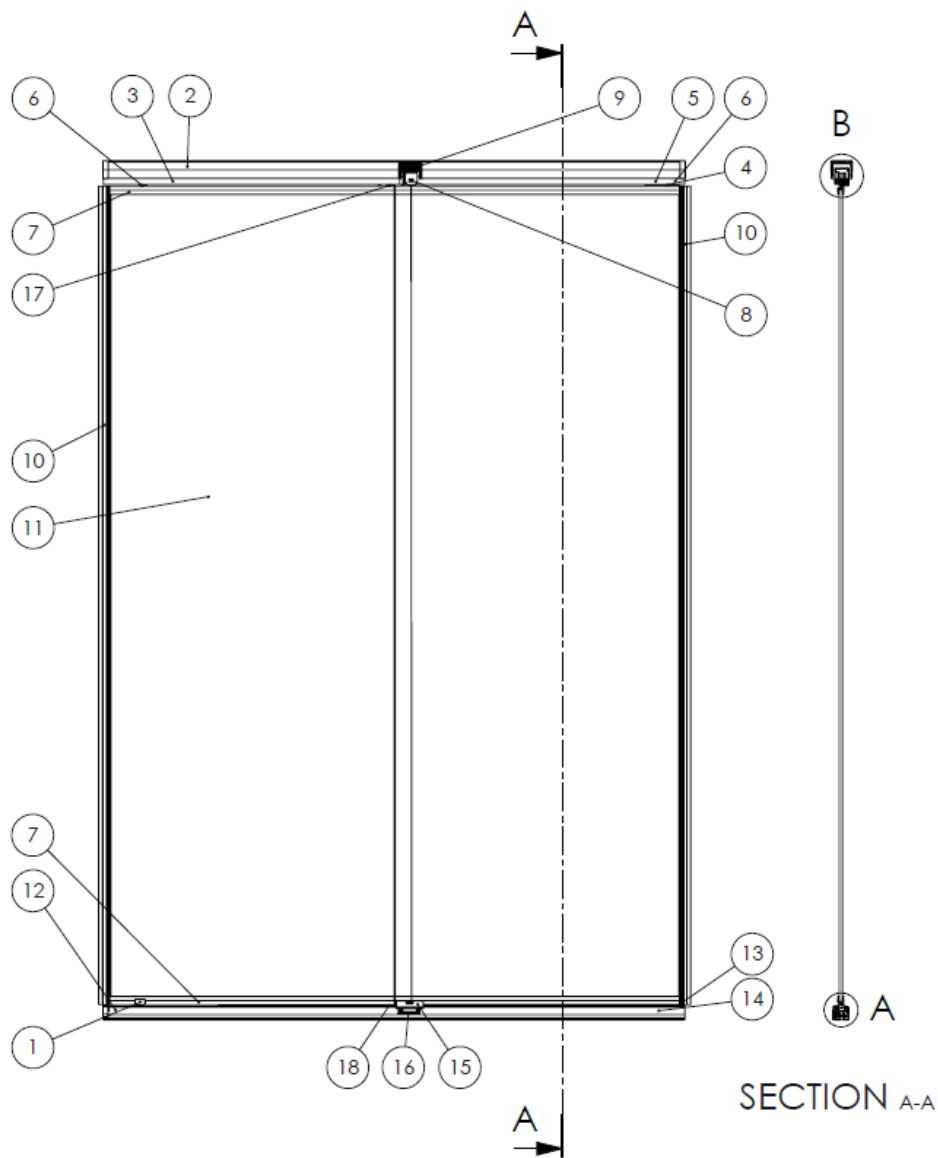

	Item number	Name	
1	50250003	Lower rail guide strong LG	Plastic
2	11222206	Telescopic profile L5/LGR	Aluminium
3	11251205	Upper profile strong LGR	Aluminium
4	53240020	Additional locking component LGR	Plastic
5	53240015	Upper chamber 6 LGR	Plastic
6	50240005	Upper rail guide strong LGR	Plastic
7	11245233 11255234 11255235	Glazing bead 8mm LGR Glazing bead 10mm LGR Glazing bead 12mm LGR	Aluminium
8	50240008	Upper latch LG	Plastic
9	53240021	Follower L LG	Plastic
10	54042024	Edge seal 30mm	Silicone
11		Toughened glass 8mm Toughened glass 10mm Toughened glass 12mm	Glass
12	11253001	Lower profile strong LG	Aluminium
13	50250001	Lower start hinge strong LG	Plastic
14	50240012	Lower chamber 6 LG	Plastic
15	50240009	Lower latch LG	Aluminium / Plastic
16	50000102	Lower hole frame reinforced	Aluminium
17	50250004	Upper hinge strong LG	Plastic
18	50250002	Lower hinge strong LG	Plastic

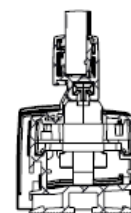

DETAIL A
SCALE 1:2

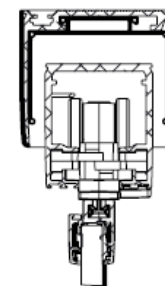

DETAIL B
SCALE 1:2

Figure 3. Example drawing of Lumon® Glazing Retractable Strong Lift Handle

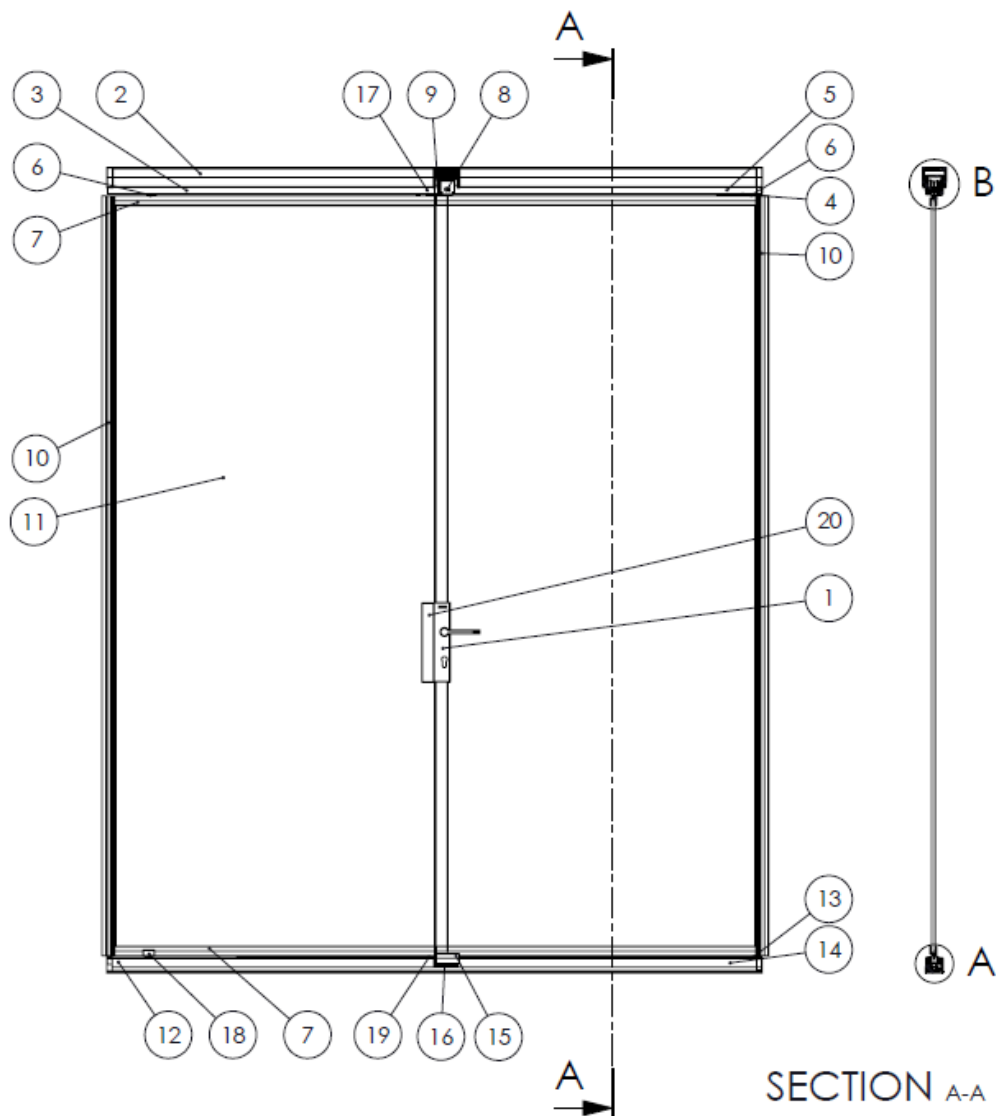

	Item number	Name	
1	50250007	Lock R	Aluminium / Steel
2	11222206	Telescopic profile L5/LG	Aluminium
3	11251205	Upper profile strong LG	Aluminium
4	53240020	Additional locking component LG	Plastic
5	53240015	Upper chamber 6 LG	Plastic
6	50240005	Upper rail guide strong LG	Plastic
7	11245233 11255234 11255235	Glazing bead 8mm LGR Glazing bead 10mm LGR Glazing bead 12mm LGR	Aluminium
8	50240008	Upper latch LG	Plastic
9	53240021	Follower L LG	Plastic
10	54042024	Edge seal 30mm	Silicone
11		Toughened glass 8mm Toughened glass 10mm Toughened glass 12mm	Glass
12	11253003	Lower profile strong LG	Aluminium
13	50250001	Lower start hinge strong LG	Plastic
14	50240012	Lower chamber 6 LG	Plastic
15	50240010	Lower high pane latch LG	Plastic
16	50000102	Lower hole frame reinforced	Aluminium
17	50250004	Upper hinge strong LG	Plastic
18	50250003	Lower rail guide strong LG	Plastic
19	50250002	Lower hinge strong LG	Plastic
20	50250010	Glass counterpart LG/LGS	Aluminium

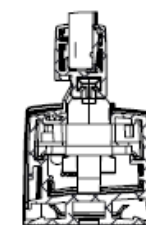

DETAIL A
SCALE 1 : 2

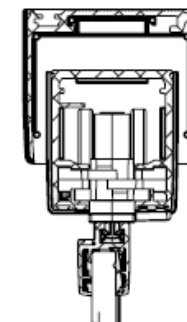

DETAIL B
SCALE 1 : 2

Figure 4. Example drawing of Lumon® Glazing Retractable Strong Middle Handle with Lock

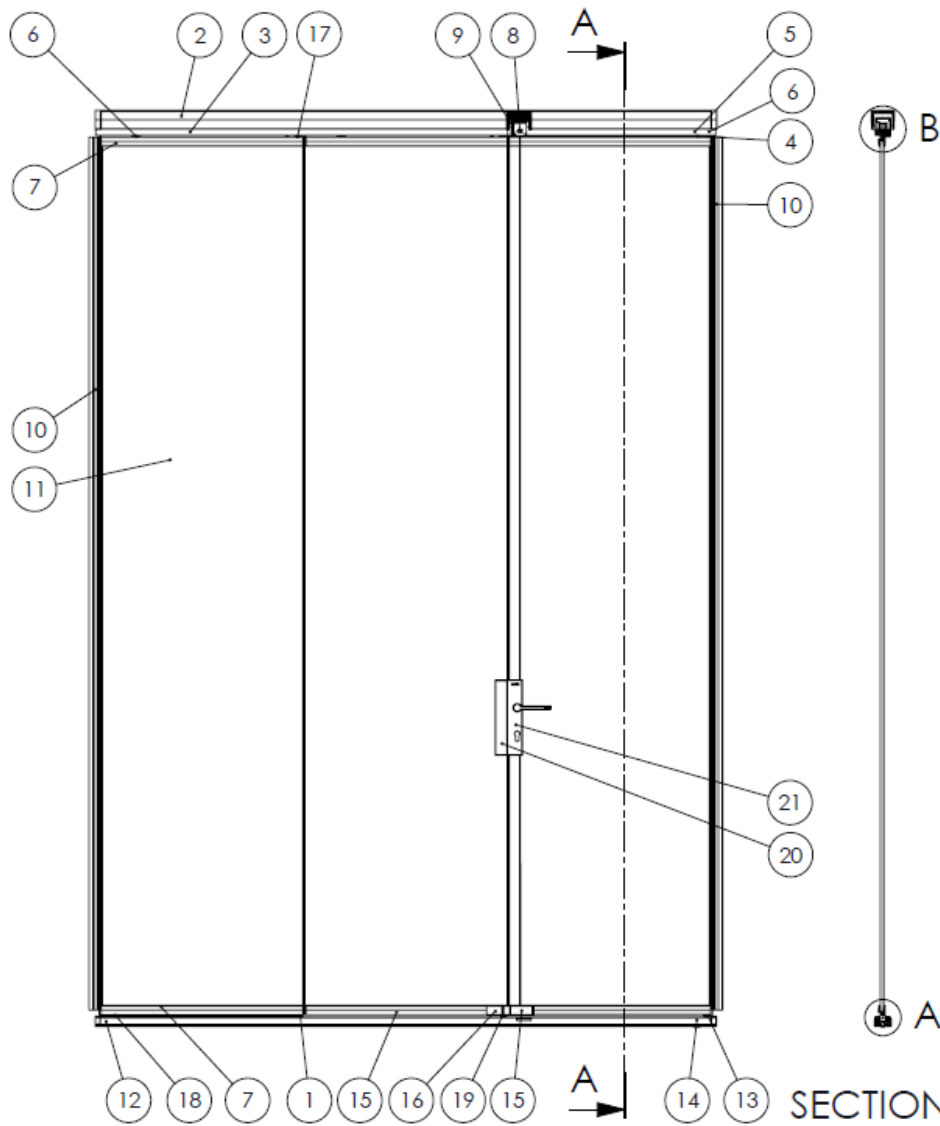

Item number	Name	
1	50250014	Lower hinge embedded LGR
2	11222206	Telescopic profile L5/LGR
3	11251205	Upper profile strong LGR
4	53240020	Additional locking component LGR
5	53240015	Upper chamber 6 LGR
6	50240005	Upper rail guide strong LGR
7	11245233 11255234 11255235	Glazing bead 8mm LGR Glazing bead 10mm LGR Glazing bead 12mm LGR
8	50240008	Upper latch LGR
9	53240021	Follower L LGR
10	54042024	Edge seal 30mm
11		Toughened glass 8mm Toughened glass 10mm Toughened glass 12mm
12	11253002	Lower profile embedded LGR
13	50250020	Lower start hinge emb. LGR
14	50240012	Lower chamber 6 LGR
15	50250013	Lower latch embedded LGR
16	51250028	Latch counterpart embedded LGR
17	50250004	Upper hinge strong LGR
18	53250019	Pin for last pane embedded LGR
19	50250021	Lower hinge 2.pane emb. LGR
20	50250010	Glass counterpart LGR/LGS
21	50250007	Lock R

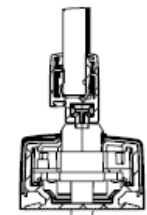

DETAIL A
SCALE 1 : 2

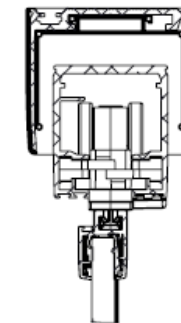

DETAIL B
SCALE 1 : 2

Figure 5. Example drawing of Lumon® Glazing Retractable Low Threshold Strong Middle Handle with lock